

SURE-TRIP

DC-2004

**PROGRAMMABLE CURRENT
MEASUREMENT**

**SURE-TRIP
RETRO KITS**

**DC CIRCUIT BREAKER
SOLID STATE CONTROLS**

All Solid State Tripping Systems Have Been Designed, Tested,
And Produced To All Applicable NEMA and UL Standards.

Patent No. 4,866,557

703A Concord Road
Albemarle, NC 28001
TOLL FREE: (877) 937-8747

SURE TRIP 2004 DC SOLID STATE PROGRAMMER

The **SURE TRIP DC-2004** DC solid-state programmer is a current monitoring device that is designed to work with either Current Sensors or existing Current Shunts. When retrofitted on DC air circuit breakers the programmer will provide more precise tripping characteristics than the thermal trip units, which it normally replaces. With unparalleled reliability, service, and versatility, the **SURE TRIP DC-2004** is the only DC Retrofit kit in its class. Both are a single unit configuration, which contains a switching power supply that is protected against transient voltage.

Both versions of the programmer come with 'Long Time', 'Short Time', and 'Instantaneous' as standard trip functions. The ability to defeat these functions using the 'Defeat' switch eliminates the need to special order the units. An 'LED' provides visual indication for each function that has been defeated. 'Loss of Voltage', and 'Trip Test', are also standard trip functions but cannot be defeated unless requested at the time of order. Trip indicators, trip indicator reset switch, power indicator light, amp tap switch, and pick-up lights are all standard features of the unit. These features are discussed in greater detail in the following pages. 'Reverse Current', 'Rate-Of-Rise', and a 'Communications Interface' capability are offered as optional equipment.

The Shunt version also has additional features. When utilizing the existing Current Shunt the trip unit is capable of sensing a 'Broken Wire' on the Shunt Inputs and provides a trip pulse to the Relay.

SURE TRIP DC RETRO-KITS OFFER THESE FEATURES

1. Circuit design provides universality of time-current settings to allow one model for the full range of current settings required by normal and special applications.
2. Rotary switch adjustments provide precise, definite, and repeatable settings.
3. Each printed circuit board is treated to prevent contamination and signal leakage.
4. Metal enclosure, as standard, to shield against noise, magnetic interference and contamination.
5. Target diagnostic circuitry is designed to provide maximum protection capability to reduce system downtime by analyzing any over current fault and visually identifying it's cause as an overload, short circuit or ground fault. Additionally, no batteries are required to maintain trip indication.
6. A Long Time pickup timing indicator, as standard, to aid in identifying an over current condition in process.
7. Circuit design allows for both local and remote fault indications. An optional feature can be added so that the unit can be interfaced with an existing Communication's System, Bell Alarms, or Lights.
8. Circuitry built for protection against RF radiation and transient voltage.
9. All Actuators are manufactured to stringent design criteria for mounting on a wide range of circuit breakers with minimum expense.
10. Actuators are manufactured with metals that inhibit corrosion to prevent inoperable mechanisms.
11. True RMS measurement on all inputs: DC, AC, or DC&AC.

SHUNT MODEL

1. Input voltages isolated at 1500VDC continuous, 2500V peak.
2. No High Current Test Sets needed to test trip unit, milli-volt source is all that is required.

SENSOR MODEL

1. Current sensors are epoxy encapsulated as standard.
2. Current sensors are designed to mount on the rear of the breaker for maximum ease of retrofitting circuit breakers. No special copper to mount internally.
3. Unit can be tested using a standard AC High Current Test Set.

Our full range of **SURE TRIP DC RETRO-KITS** allow our customers to update any circuit breaker with the features required for the various applications demanded with both cost and feature benefits that are unprecedented in the marketplace.

SURE TRIP DC RETRO-KITS

CONTROL POWER

The logic controller will be powered by applying a voltage source to the 'CONTROL VOLTAGE' inputs. This can be accomplished either by using the Control Voltage present on the breaker or by wiring to the Line Side Bus. While the voltage can be DC or AC, it should be constant and should not exceed 300V peak. Utilization of the Control Voltage is the most common and preferred method. **Never Hi-Pot the breaker after wires are installed.*

The operating range of the logic is 100 - 300VDC or 85 - 240VAC as a standard. Other requirements can be accommodated by special order. The Power LED on the front of the logic will be lit when Power is applied to the Logic. If the LED is not lit there is no protection on the breaker.

The 'CONTROL VOLTAGE' inputs of the logic have a transient suppression network to prevent failure of the Logic. The added protection on the Power Supply within the Logic Controller has been designed to survive a Transient Voltage Spike with amplitudes of 1000 volts for 10 milli-seconds. Conditions in excess of this criterion will have to be handled on a customer level or upgraded protection can be supplied from the factory on special orders.

If power failure occurs the Logic will trip the breaker and the Target Indicator will flip indicating a Loss of Voltage trip. This function can be defeated by special order. After a Loss of Voltage trip has occurred, reapply power to the Logic and verify that the power LED is lit before closing breaker.

CURRENT SENSORS

The current sensors are designed to be mounted on the rear bus-bar stabs of the circuit breaker. They produce a voltage output that is proportional to the load current of the breaker. The sensors can be set to monitor any level of current, up to a maximum of 15,000 amps, depending on the customer's requirement. Using the 'AMP TAP' switch on the logic controller, will further enhance the coordination of the unit after it has been installed on the breaker

The sensor unit can be used with single or dual sensor protection.

SHUNTS

The Shunt version of the unit is designed to work with existing current shunts in the power system. This unit is extremely useful when the customer has existing metering in the cubicle and wants to add protection. The unit can be mounted within the cubicle or breaker. The control or bus voltage in the cubicle is used to power the unit. The Current Shunt is wired directly to the unit at the inputs. A trip relay can be wired in series with the Shunt Trip device to open the breaker on a fault condition.

The shunt unit can be used with single or dual shunt protection. The dual shunt feature enables the monitoring of the current in separate bus bars without sacrificing the isolation. The unit wires as a normal DC-2000 with the exception of the additional two-terminal connector located on the top of the logic box. The shunt polarity should be observed when wiring. The plus position of the terminal block should wire to the more positive, high side, of the shunt with the negative position connected to the low side. Improper or loose connections may prevent the unit from functioning properly.

ACTUATORS

Actuators are manufactured to mount on standard breaker frames with minimal time and expense. With a minimum of 6 pounds holding and tripping, they will trip the breaker when required and at the same time, eliminate nuisance tripping.

TRIP RELAY

The Trip Relay, if supplied, will be contained in the logic controller. The Relay is a Solid State Relay and can be set up as Normally Open or Normally Closed contacts. The contacts can be used in conjunction with existing apparatus, i.e. Shunt Trip or Undervoltage, to open the breaker on a fault condition. The Positive and Output points of the Relay are available at the left side terminal block. Polarity must be observed when wiring the Relay terminals to insure proper operation. Improper connections may cause the Relay to fail, thus preventing the logic from opening the breaker on a fault condition. The relay is internally protected against transient voltages that could damage it. Relay contacts are rated to handle 300 VDC, 6 ADC maximum. For other requirements please contact the factory.

DC-2004 FUNCTIONS

LOSS OF VOLTAGE PROTECTION

In the event there is a voltage drop, below approximately 100 VDC, the DC Programmable Logic Control will loose power causing the breaker to trip and the Loss of Voltage target indicator to flip to yellow. This function can only be defeated at the factory and must be requested at the time of order. When this function is defeated, the unit will not trip upon loosing power, which will allow the breaker and/or equipment to operate without protection. This range of operation can be adjusted to allow for lower voltages. Please call for details.

BROKEN WIRE PROTECTION

The Shunt version has the ability to sense an open wire on either or both of the Shunts inputs. When an open wire condition occurs, the 'Broken Wire Pick-Up' LED will light and the logic will go into a fault condition and cause the breaker to open without intentional time delay. The 'Broken Wire' LED trip indicator will light to show the cause of the trip. The 'Broken Wire Pick-Up' LED will remain lit until the open input is repaired or power is removed from the logic controller. This feature can only be defeated at the factory.

REVERSE CURRENT PROTECTION

Low-level reverse current protection may be required in some applications. For these applications, the 'Reverse Current' protection is offered as optional equipment. The Pick-Up level and time delay is preset at the factory according to the customer's specifications. The Pick-Up level will be fixed at a predetermined level of current, minimum setting is 10% of the input.

TRIP TEST

The 'Trip Test' feature provides a simple method of testing the tripping action of the breaker or contactor that is being protected. After installing and powering the logic controller you can test the tripping of the unit by inserting a paper clip into the hole in the lower right hand side of the faceplate. A push button switch located behind the faceplate of the logic controller will click when depressed and the unit should cause the contacts to open. The 'Trip Test' LED will light to indicate the trip and can be reset by pressing the 'Indicator Reset' Switch.

COMMUNICATIONS INTERFACE OPTION

The optional 'Communications Interface' provides the user with the ability to interface the DC Logic Controller with an existing communication system or with a new system such as "Power Measurements". The interface also gives the customer the ability to interface with external enunciators, i.e.: Bell Alarms, Lights, etc. The interface is contained within the original unit and has no additional mounting requirements other than the wiring. It consists of a set of normally open dry contact outputs that represent the trip functions of the logic. There outputs are available through a second terminal block located on the right side of the Logic Controller. The respective output will latch closed on a fault condition and will remain closed until it is reset. Reset will occur when the 'INDICATOR RESET' switch is pressed or when the 'Remote Reset' terminals on the 'CI' terminal block are shunted.

The following outputs are available; 1> Trip Relay, 2>Long Time Trip, 3> Short Time Trip, 4> Instantaneous Trip, 5> Broken Wire Trip, 6> Loss of Voltage Trip, 7> Reverse Current, 8> Rate-Of-Rise. The relays can be reset using the 'Indicator Reset' switch on the logic controller or remotely using a contact closure across the remote reset terminals. A connector is supplied on the right side of the logic controller that allows access to each of the required outputs and the remote reset.

RATE-OF-RISE

Designed in conjunction with "Chicago Transit Authority", this function applies primarily, but is not limited to DC transmission systems for rail or transit lines. This function senses the rate at which the current rises as a function of time. The current does not have to achieve a certain amplitude to trip such as with the Short Time or Instantaneous functions. The settings for Pick-Up are based on multiples of the value of the current shunt within the power system. The Pick-Up controls consist of two potentiometer adjustments that are continuously variable from below 1x/second to above 9x/second. The controls are a 'Coarse' and a 'Fine' adjustment. The 'Delay' is a variable adjustment from less than 50 milli-seconds to over 300 milli-seconds. The range on the pick-up control can be varied at the factory if so desired to allow for more selectivity in the specified range. If the Pick-Up level and the Delay are both exceeded the 'R-O-R' circuit will send a trip pulse to the relay output of the logic controller and the target 'Trip Indicator' for the 'R-O-R' will flip.

The unit attaches to the top of the **SURE TRIP DC-2004** logic programmer and ships from the factory as a single unit. There is no additional external wiring or mounting required with the R-O-R attachment.

DESCRIPTION OF STANDARD FEATURES

The list below shows the features that are included on the **SURE TRIP DC-2004**. The information that follows gives a brief description of each of these features.

<ol style="list-style-type: none"> 1. Amp Tap Switch 2. Long Time Pick-Up 3. Long Time Delay Band Adjustment 4. Short Time Pick-Up 5. Short Time Delay Band Adjustment 6. Instantaneous Pick-Up 	<ol style="list-style-type: none"> 7. Trip Indicating Targets and LED's 8. Function Defeat Switch 9. Pick-Up LED's 10. Power LED 11. Trip Test Button
-------------------------------------------------------------------------------------------------------------------------------------------------------------------------------------------------------------------------------------------------------------	----------------------------------------------------------------------------------------------------------------------------------------------------------------------------------------------------------

AMP TAP SWITCH (#1)

The six-step adjustable ampere setting from 50% to 100% varies the level of current the logic monitors from the Current Shunt or Sensor in 10% increments. Changing this setting has the same effect as changing the value of the Shunt or Current Sensor.

Example:

With a 1600 amp Current Shunt or Sensor, 'Amp Tap' switch setting at .5 equals 800 amps maximum current, with 'Long Time', 'Short Time', and 'Instantaneous' Pick-Ups coordinated to the 800 amp level.

LONG TIME PICK-UP (#2)

The 'Long Time Pick-Up' switch provides additional adjustable current capabilities of the breaker with seven steps from 40% to 100% in 10% increments. When used with the 'Amp Tap' switch the breaker can monitor a continuous current between 20% and 100% of the current rating. Changing this setting does not affect any other function.

Example:

With a 1600 amp Current Shunt or Sensor, 'Amp Tap' Switch setting at 1, 'Long Time Pick-up' set at .4x equals a 640-amp 'Long Time' Current rating. This means the breaker can have a maximum continuous current of 640 amps without tripping.

LONG TIME DELAY BAND ADJUSTMENTS (#3)

This three-step adjustment varies the length of time that the breaker will operate under sustained overload without tripping. These times vary with the overload amplitude relative to the 'Long Time Pick-Up' setting. The higher the overload the quicker the trip times. The time-current curve shows the tripping characteristics of the 'Long Time' function as it relates to the level of the overload current.

SHORT TIME PICK-UP (#4)

This function controls the amount of high current the breaker can carry for short periods of time without tripping. A ten-step switch allows selectability between 150% and 1000% of the Current rating as a multiple of the 'Amp Tap' Switch setting.

Example:

With a 600 amp Current Shunt or Sensor, 'Amp Tap' Switch setting at .5, 'Short Time' Pick-up set at 10 times equals a 3000 amp 'Short Time' Current rating.

SHORT TIME DELAY BAND ADJUSTMENT (#5)

This three-step delay adjustment provides further coordination between circuit breakers. It allows the breaker a time interval before responding to the selected 'Short Time' Pick-Up current level.

INSTANTANEOUS PICK-UP (#6)

This function determines the level at which the breaker will trip without adjustable time delay. This instantaneous interruption occurs only as a result of a severe short circuit within .06 second of the fault condition.

TRIP INDICATING TARGETS AND LED'S (#7)

These fault indicators identify the cause of a trip and help reduce system down time by allowing the user to more quickly diagnose the problem. Four electronic flip-flag indicators analyze the fault and provide a memory of the trip for 'Long Time', 'Short Time', 'Instantaneous', and 'Loss-Of-Voltage' functions. Two LED's provide indication for 'Broken Wire' and 'Trip Test'. The 'Indicator Reset' switch located at the upper right side of the trip indicators resets the Trip Indicating Targets and LED's after a fault condition.

FUNCTION DEFEAT SWITCH (#8)

The 'Function Defeat' switch allows the user to customize the logic trip functions as the need demands. The 'Long Time' can be defeated along with the 'Short Time' or 'Instantaneous'. The 'Short Time' and 'Instantaneous' functions cannot be defeated at the same time.

PICK-UP LED'S (#9)

There are two Pick-Up LED's that provide information on the 'Long Time' and the 'Broken Wire'. The 'Long Time Pick-Up' LED provides visual indication that an overload condition exists and the long time timing function has started. When the LED turns off the timing function is reset and starts over when the LED turns on again. The 'Broken Wire Pick-Up' LED shows the status of the Shunt Input leads. If either or both of the input leads lose connection, this LED turns on and remains on until the leads are secured.

POWER LED (#10)

This feature provides visual indication to show that the logic controller is operating properly. The LED will remain lit until the 'Control Voltage' to the logic is disconnected.

TRIP TEST BUTTON (#11)

The 'Trip Test' button provides a simple method of testing the tripping action of the breaker or contactor that is being protected. After installing and powering the logic controller you can test the tripping of the unit by inserting a paper clip into the hole in the lower right hand side of the faceplate. The push button switch is located behind the faceplate of the logic controller and will click when depressed. The unit should cause the contacts to open and the 'Trip Test' LED will light to indicate the trip. The LED can be reset using the 'Indicator Reset' Switch.

Communications Interface Pinout

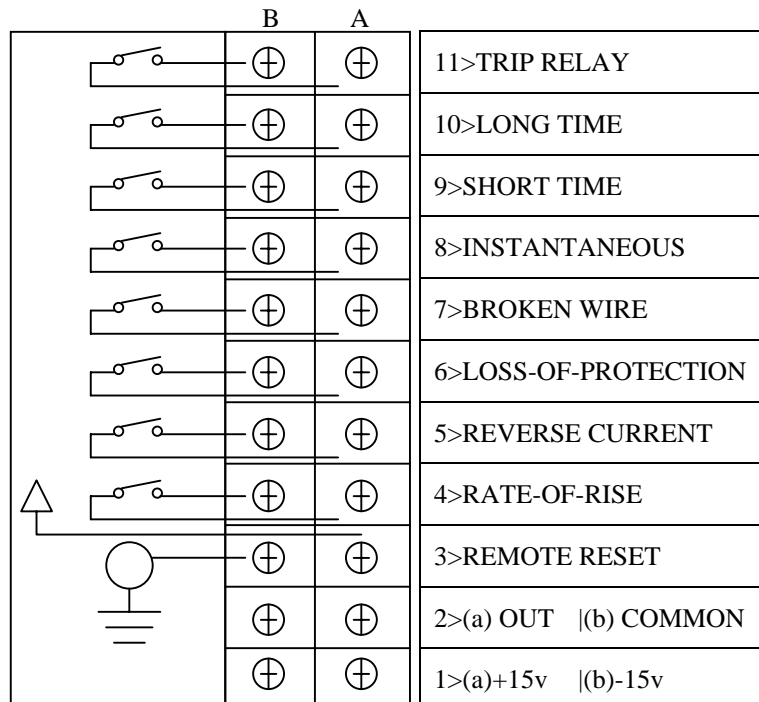

SURE TRIP DC-2004S

SHUNT GENERAL INSTALLATION INSTRUCTIONS

Mount the logic control near the front of the breaker or cubicle so that the switches and indicators can easily be accessed. Mounting brackets will be provided on standard breaker frames. Care should be taken not to block access to any of the Switches, Targets, or LED's when mounting the logic controller. Specific breakers will have different mounting depending on established designs.

With Single Shunt:

The logic controller has three terminal blocks located on the unit. The terminals are labeled on the faceplate to show the designation for each position. The top terminal block has two positions and is used for the Current Shunt inputs.

With Trip Relay:

The Logic Controller has a Solid State Relay built into the unit. This Relay comes standard with a set of Normally Open contacts. The contacts can be used in conjunction with existing apparatus, i.e. Shunt Trip, to open the breaker on a fault condition. The Positive and Output connection of the Relay are available at the lower left side terminal block, 2 position. Polarity must be observed when wiring a DC Trip Relay to insure proper operation. Improper connections may cause the Relay to fail, thus preventing the logic from opening the breaker on a fault condition.

Relay contacts are rated to handle 300 VDC, 6 ADC maximum. For other requirements please contact the factory.

Wiring:

Refer to the wiring diagram on page 8. The Shunt should be connected to the Logic Controller using a two- (2) conductor, or more, shielded cable. The cable should be a minimum size of 18-Awg wire and have a voltage withstand rating sufficient to handle the Bus Voltage. Connect the High Side and the Low Side of the Shunt to the corresponding input terminal on the logic controller. The Shield can be terminated at the Low Side of the Shunt or to Field Ground. Do not attach the shield from the cable to both the Shunt and Field Ground at the same time. The Logic should not be powered until the shunt is connected.

The logic controller can be powered by using either the Control Voltage present on the breaker or by wiring to the Bus. The voltage should be constant and should not exceed 300VDC. Utilization of the Control Voltage is the most common and preferred method. Connect the positive voltage and the negative voltage on the breaker to the corresponding terminals on the 3-position terminal block of the left side of the logic. Connect the 'Field Ground' terminal to the breaker frame or Field Ground. ****Never Hi-Pot the breaker after the wires are installed.***

Use caution when routing any of the wiring within the Breaker frame. Moving parts must not come in contact with the wires at any position. All wiring should be fastened securely to prevent any movement after breaker has been put into service. The length of the shielded cable should be kept to a minimum.

After wiring, the breaker should be tested per the trip curves. When primary injection or secondary testing the breaker, the 'Control Voltage' terminals may be connected to 120 VAC or 220 VAC. The Power LED will be lit whenever the Logic Controller has proper supply voltage. Overvoltage will cause serious damage to the unit so caution should be used when selecting the supply voltage.

SURE TRIP DC-2004S SHUNT CONNECTION DIAGRAM

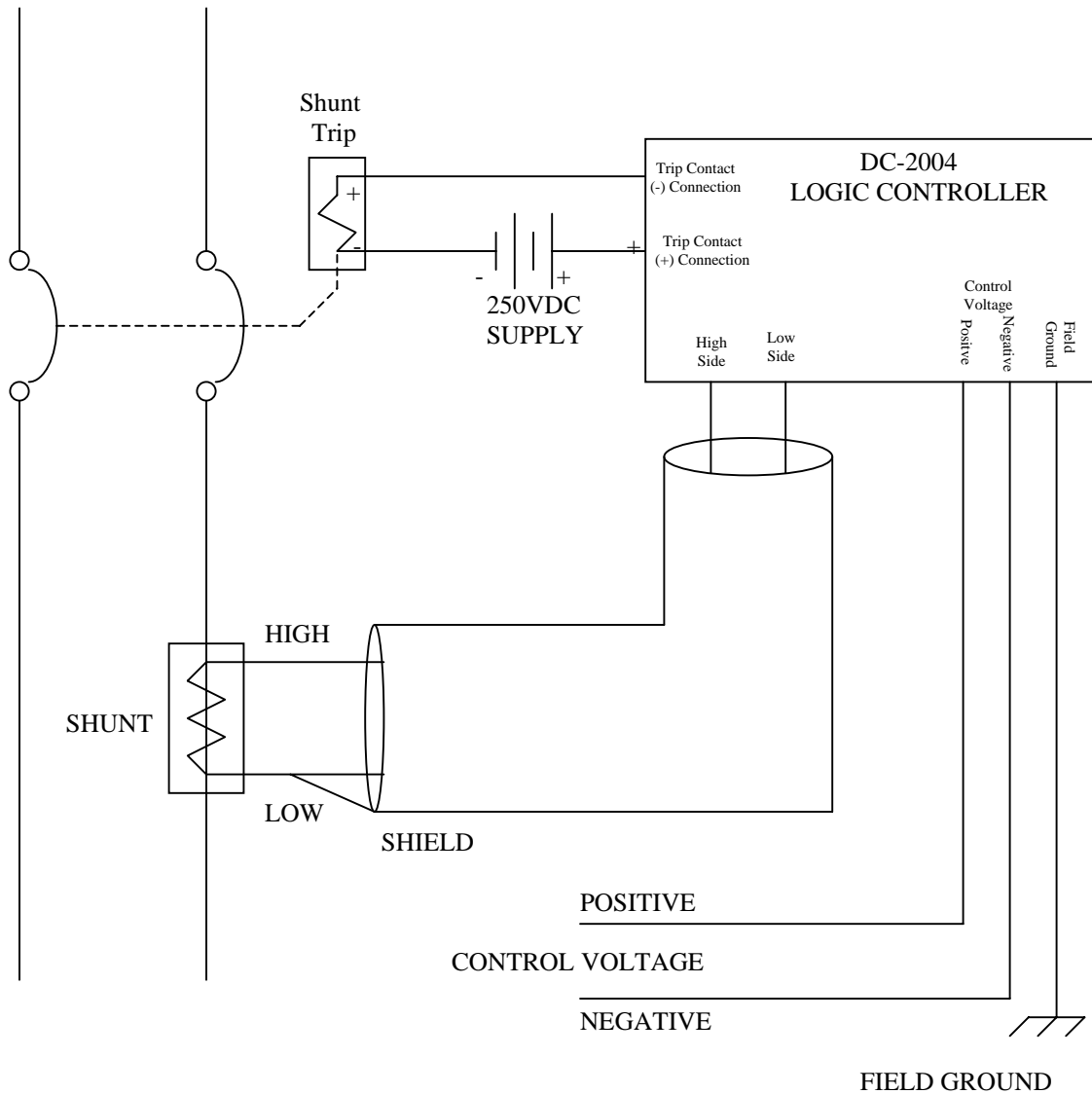

Caution:

Do not Hi-Pot the Breaker with wiring installed on logic Controller. This may cause extensive damage to the unit.

Note:

- *Shielded Cable should be used when wiring Shunt to Logic Controller.*
- *Shield should be terminated as shown above in the Connection Diagram.*
- *Minimum 16 Awg wire should be used on Control Voltage and Field Ground terminals.*
- *All wiring should be completed before power is applied to the Logic Controller.*

DC-2004

SENSOR GENERAL INSTALLATION INSTRUCTIONS

With Single Sensor:

Install the positive sensor on the bus bar making certain the terminal side is facing the positive supply. Center the sensor on the bus bar and secure it. The sensor(s) can be mounted on the line or load side of the breaker.

With Dual Sensor:

The positive sensor is put on the positive bus as per above and the negative sensor is put on the negative bus, with the terminals facing towards the negative supply. Refer to wiring diagram below. In addition to the 9 position terminal block on the front-left side of the unit, there will be a second terminal also located on the left side. The two terminal block is used for connecting the #3 and #4 Sensor Terminals.

Mounting brackets and hardware are supplied for mounting the Retrofit kit on the breaker. Mount Kit per mounting instructions. If brackets and instructions are not available for a specific breaker type, a 1" x 2" x 9.5" piece of aluminum angle will be supplied. Care should be taken not to block access to any of the Switches, Targets, or LED's when mounting the logic controller. Four (4) 8-32 x 3/4" bolts are provided to mount the logic box on the bracket and the bracket to the frame. Specific breakers may have different mounting depending on established designs.

With Actuator:

If the unit is supplied with an actuator, it will mount per the mounting instructions. Make certain all mechanical linkages are adjusted and tested properly.

Wiring:

Refer to wiring diagram on page 11. The logic has a 3 terminal blocks that are accessible from the front of the unit. The positions of each terminal are labeled on the faceplate to show the designation for each position.

The 3 position terminal block is used for connecting the 'Field Ground', 'Negative Control Voltage', 'Positive Control Voltage'. The 2 position terminal block is for the Actuator or Relay output. The 6 position terminal block located at the top of the unit is used to connect the Sensors.

Mount the latch per the circuit breaker mounting instructions for the breaker type that the unit is being installed on. Mounting brackets and hardware are supplied for mounting the latch on the breaker.

If the Logic Controller is supplied with Solid State Relay rather than a latch, it will be built into the unit. The outputs of the Relay are available at the left side terminal block. Polarity must be observed when wiring the Relay output terminals to insure proper operation. Improper connections may cause the Relay to fail, thus preventing the logic from opening the breaker on a fault condition. Relay contacts are rated to handle 300 VDC, 6 ADC maximum. For other requirements please contact the factory.

Use caution when routing any of the wiring within the Breaker frame. Moving parts must not come in contact with the wires at any position. All wiring should be fastened securely to prevent any movement after breaker has been put into service. The length of the shielded cable should be kept to a minimum.

Positive Sensor: Using the four conductor shielded cable, connect the 'Term #1' terminal on the logic to the #1 terminal on the sensor using the Red wire from the shielded cable. Connect the 'Term #2' terminal on the logic and the Cable Shield to the #2 terminal on the sensor using the Black wire. Connect the 'Term #3' terminal on the logic to the #3 terminal on the sensor using the White wire. Connect the '- Vin' terminal on the logic to the #4 terminal on the sensor using the Green wire. The shield should be connected to the #2 terminal on the positive sensor.

Negative sensor (If Supplied): Using the second four conductor shielded cable, connect the #1 terminal on the sensor to the 'Term #1' terminal on the logic using the Red wire from the shielded cable. Connect the 'Term #2' terminal on the logic and the Cable Shield to the #2 terminal on the sensor using the Black wire. Connect the #3 terminal on the negative sensor to the 'Negative Sensor Term #3' terminal on the logic using the White wire.

Connect the #4 terminal on the negative sensor to the 'Negative Sensor Term #4 terminal on the logic using the Green wire. The shield should be connected to the #2 terminal on the negative sensor.

Each shield in the wiring is connected to the #2 terminal of the *Positive and Negative Sensor, respectively.*

If the unit is supplied with a latch, a set of 22-Awg white and black wires will also be supplied. Connect the White wire between the 'Latch Positive' terminal on the logic and the latch positive (white wire). Connect the Black wire between the 'Latch Negative' terminal and the latch negative (black wire).

If the unit has a Solid State Relay built into it, an installation page will be included in the shipment to describe in detail the wiring connections.

The logic controller can be powered by using either the Control Voltage present on the breaker or by wiring to the Bus. The voltage should be constant and should not exceed 300VDC. Utilization of the Control Voltage is the most common and preferred method. Connect the positive voltage and the negative voltage on the breaker to the corresponding terminals on the terminal block. Connect the 'Field Ground' terminal to the breaker frame or field ground. **Never Hi-Pot the breaker after wires are installed.*

After wiring, the breaker should be tested per the trip curves. When primary injection or secondary testing the breaker, the 'Control Voltage' terminals may be connected to 120 VAC or 220 VAC. The Power LED will be lit whenever the Logic Controller has proper supply voltage. Overvoltage will cause serious damage to the unit so caution should be used when selecting the supply voltage.

DC-2004 CONNECTION DIAGRAM

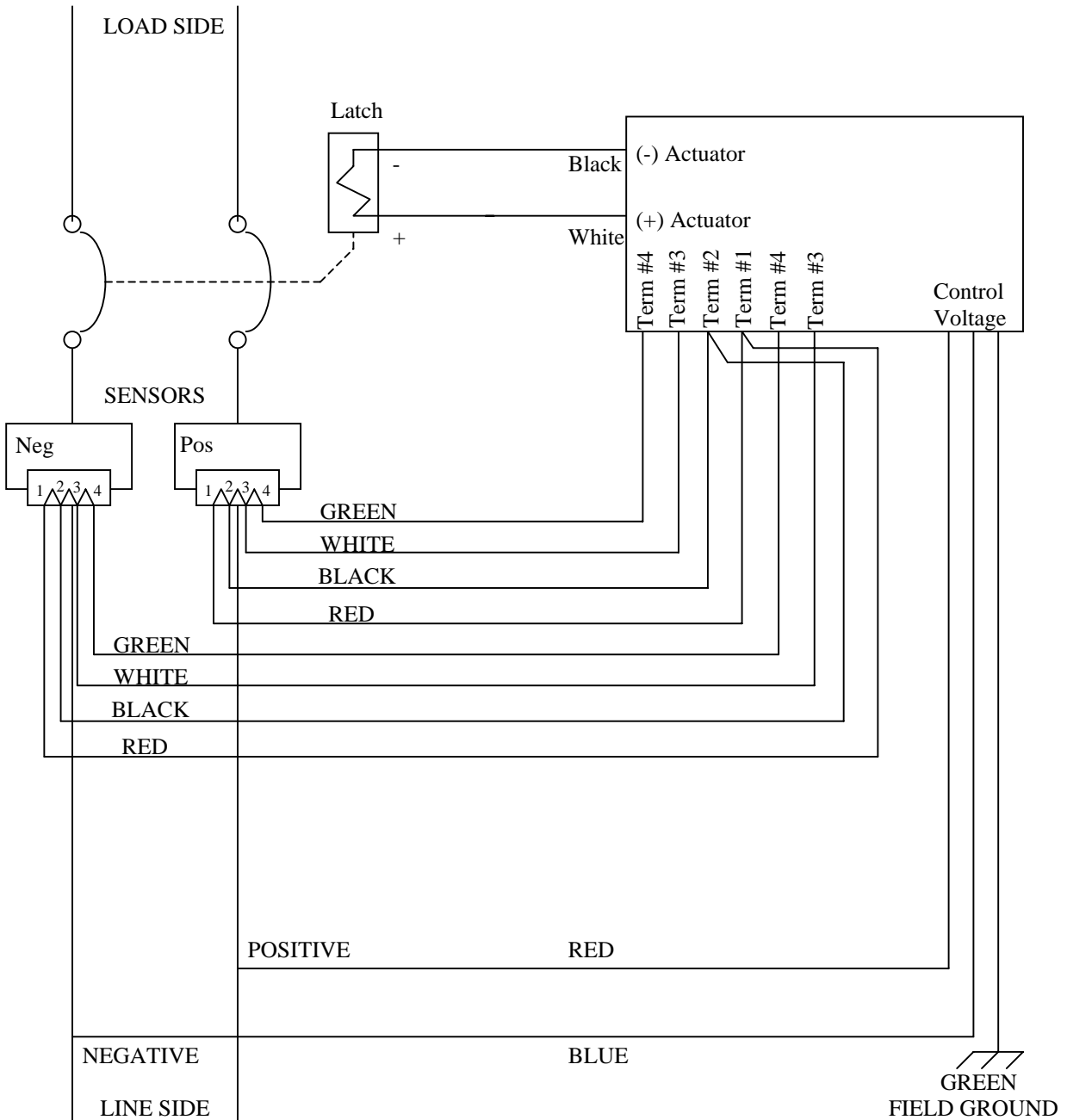

Caution:
Do not Hi-Pot the Breaker with wiring installed on logic Controller. This may cause extensive damage to the unit.

LATCH

White Latch White to Logic Terminal 'Positive Latch'
 Black Latch Black to Logic Terminal 'Negative Latch'

SHIELDED CABLE

Red Sensor Terminal #1 to Logic Terminal '+Ix'
 Black Sensor Terminal #2 to Logic Terminal '-Ix'
 White Sensor Terminal #3 to Logic Terminal '+Vh'
 Green Sensor Terminal #4 to Logic Terminal '-Vh'

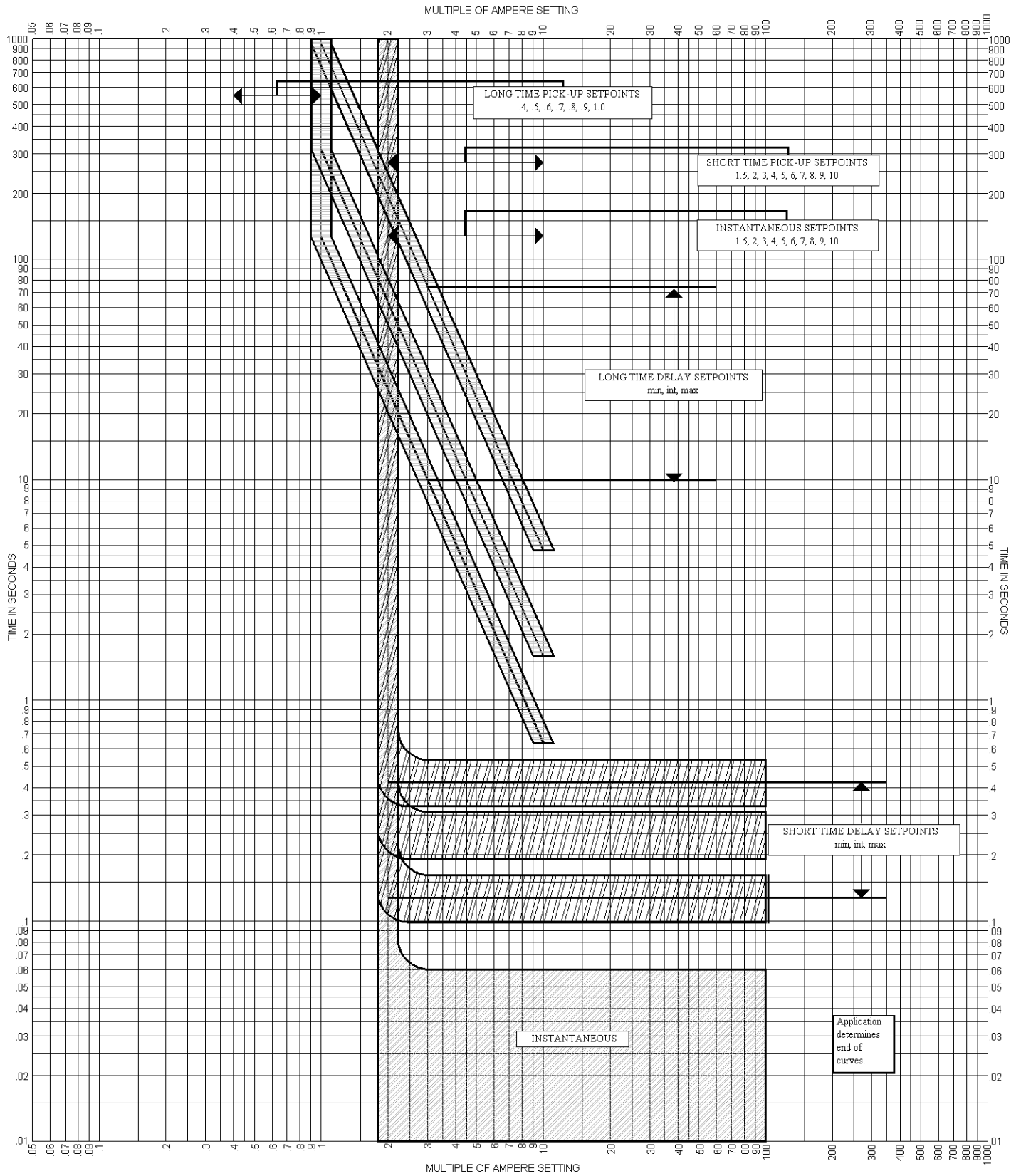

DC-2004 Programmable Logic Controller TIME-CURRENT CHARACTERISTIC CURVES
 FOR WESTRIP DATED APRIL 1, 2005
 STANDARD DEVIATION FOR AMPERE SETTING IS +/- 10%
